

Technical features

GPS antenna



General features :

- ▶ 12-channel receiver L1 = 1 575 MHz.
- ▶ Data standard : NMEA 0183
- ▶ Data transmission : RS485, 4800 bauds, 8 data bits, 1 stop bit, no parity.
- ▶ The antenna delivers every second the time message ZDA then GGA.
- ▶ Power supply : 5 to 15 V DC (provided by the system connected).
- ▶ Horizontal and outdoor installation on the roof or on a mast.
- ▶ Possibility to install the antenna behind a window or under a plastic roof.
- ▶ Cable is 4 wires section 0.6 mm², a 20-m cable is provided with the antenna.
- ▶ Possibility to extend the cable length up to 100 meters.
- ▶ Grey ABS casing with swivelling support to point the sky, fixing with 1 screw Ø 4 mm.
- ▶ Operating temperature : -30 to +70 °C.
- ▶ Storage temperature: -40 to +85 °C.
- ▶ IP67 protection.

Operation :

- ▶ A yellow LED indicates the operation of the antenna.
- ▶ The LED flashes every second when the antenna is synchronised.
- ▶ The LED remains on when the antenna is not synchronised.
- ▶ The LED is off, if the antenna is not supplied with power.
- ▶ The LED is visible from under.

Norms :

- ▶ EN 60950 : safety of information technology equipment,
- ▶ EN 61000-6-1 : immunity standard of information technology equipment,
- ▶ EN 61000-6-3 : emission standard of information technology equipment.

Power DC	5V	15V
Consumption	70mA	30mA
Maximal cable length	25m	100m

Dimensions in mm

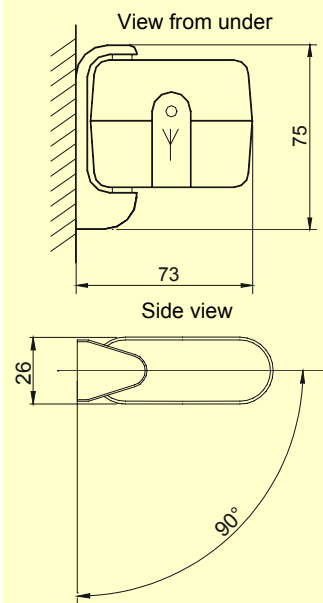

Reference :

- ▶ GPS antenna

907 035



Bodet

Réf. 643061C